



VISHAY MCB

www.vishay.com

The DNA of tech.®

Variable Resistors

Application Note

User Manual for Linear Sensor UIPMA / UFPMA

By *Jérémy La Croix*

1. INTRODUCTION

The purpose of the user manual is to define the precautions for unpacking, mounting, and using the UIPMA... / UFPMA... series of linear motion sensors.

UIPMA



Fig. 1 - Isometric view 1

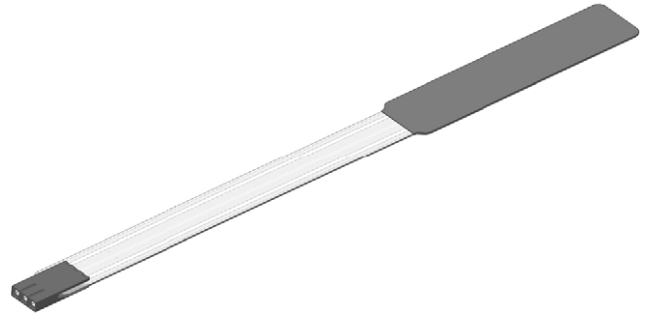

Fig. 2 - Isometric view 2

UFPMA

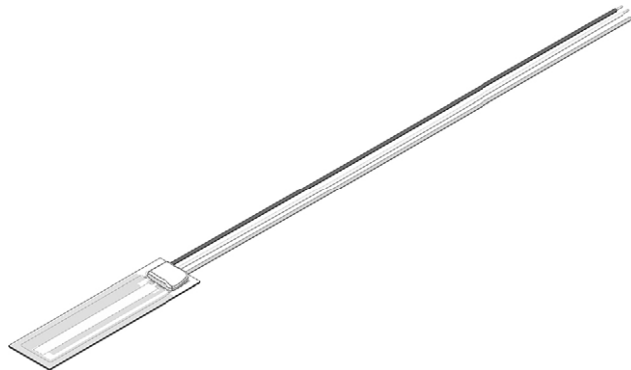

Fig. 3 - Isometric view

This products consist of resistive and collector tracks separated by a spacer. They have an adhesive zone to fix them to the customer interface. The electrical output is realized by a connector. The customer must remove the protection layer to stick the product on their interface.



The DNA of tech.®

User Manual for Linear Sensor UIPMA / UFPMA

2. MAIN CHARACTERISTICS

The devices' main characteristics are defined in its respective datasheet for UIPMA (www.vishay.com/doc?32537) or UFPMA (www.vishay.com/doc?32514).

3. PACKING CONDITIONS

UIPMA products are packaged so as to not bend during transport. The number of products per box may vary by device.

4. DELIVERY CONDITIONS

Delivery conditions may vary by device.

5. STORAGE CONDITIONS

In addition to storage temperatures written on their respective datasheets, storage conditions are also applicable:

- Recommended temperature range before gluing: 15 °C to 25 °C
- Temperature range after gluing:
see datasheets for UIPMA (www.vishay.com/doc?32537) or UFPMA (www.vishay.com/doc?32514)
- Absence of UV radiation
- Hygrometry: < 70 %
- Lifetime in storage conditions: 1 year

6. OPERATION AND UNPACKING CONDITIONS

- During product handling, the operator shall not bend the active area, which risks the deterioration of the product
- During product handling, the operator shall not bend the flat flex cable under a diameter of 3 mm

7. MOUNTING CONDITIONS

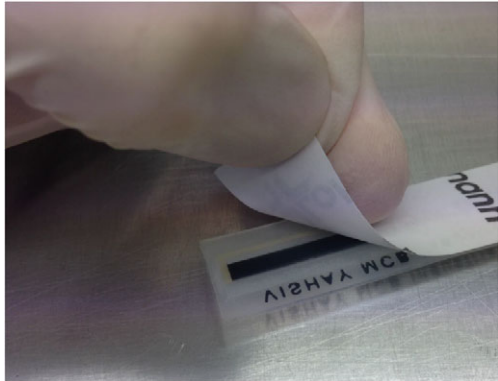
7.1 MOUNTING PROCEDURE		
OPERATIONS	PROCESSING INSTRUCTIONS AND TECHNICAL INFORMATION	PICTURES
Clean the interface	One important parameter for efficient bonding is the best possible preparation of the bonding surface in order to reach high adhesive strengths. There are generally two cleaning methods, chemical and mechanical, or a combination of both. The surfaces to be bonded must be dry and free from dust, oil, separating agents, and other contaminants. Loose paint or protective coatings must be removed. For cleaning the surfaces, only use a clean cloth in combination with material-compatible solvents like benzine, alcohol, ester, or ketones.	
Remove the protective film	Remove the protective film.	

APPLICATION NOTE

User Manual for Linear Sensor UIPMA / UFPMA

7.1 MOUNTING PROCEDURE		
OPERATIONS	PROCESSING INSTRUCTIONS AND TECHNICAL INFORMATION	PICTURES
Stick the product	Apply a contact pressure manually with a roller or surface press (approx. 10 N/cm ² to 15 N/cm ²). Full adhesive strength is only reached after at least 24 hours at normal temperatures.	

7.2 SENSOR MOUNTING CONDITIONS

Environmental

Temperature: the most favorable temperature for using pressure-sensitive adhesive tapes is in the range of +18 °C to +35 °C. If bonding is carried out at low temperatures, the initial strength of the bond will be reduced and final bond time extended

Cleaning

- Customer interface surface: the customer interface surface must be dry and free of dust, grease, oil, and separating agents. Loose paint, protective coatings, or faces need to be removed or hardened
- Cleaning: for cleaning the surfaces, only use a clean cloth and a solvent that is compatible with the materials, e. g. benzines, alcohol, esters, or ketones

Electrical

- Recommended load impedance: see datasheet for UIPMA (www.vishay.com/doc?32537) or UFPMA (www.vishay.com/doc?32514)
- Recommended current: see datasheet for UIPMA (www.vishay.com/doc?32537) or UFPMA (www.vishay.com/doc?32514)
- Example of electrical diagram:

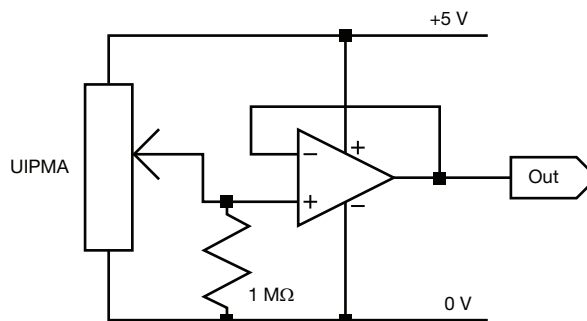

User Manual for Linear Sensor UIPMA / UFPMA

Mechanical

- Contact pressure: contact pressure (approximately 10 N/cm² to 15 N/cm²) is applied manually with a roller or surface press. Hard-type (“dry”) adhesive tape requires greater contact pressure than soft tape. Full adhesive strength is only reached in the case of hard adhesives after at least 24 hours at normal temperatures
- The flatness of the customer interface over the active area shall be under 0.05 mm
- The roughness of the customer interface over the active area shall be under 1.6 mm
- The flat flex cable must not be bent under a diameter of 3 mm
- The product accepts only one sticking
- The product must not be disassembled

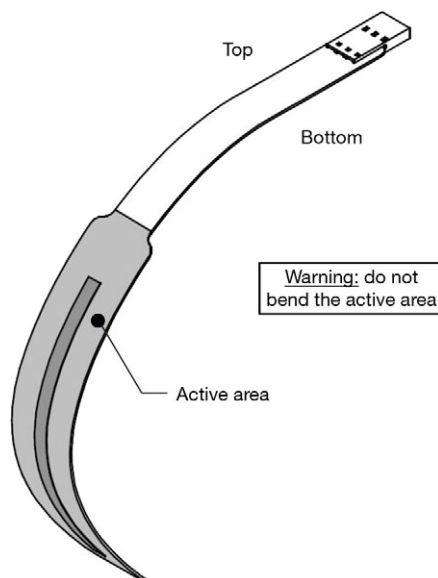

Fig. 4 - Do not bend

7.3 WIPER MOUNTING CONDITIONS

Wiper mounting conditions depend of the kind of wiper. Respective mounting conditions are defined in datasheet www.vishay.com/doc?32537, section “Pressers”.

8. USAGE CONDITIONS

The linear sensor is a potentiometric linear displacement sensor delivering a linear voltage between 0 V and the supply voltage as a function of the position of the wiper on the track. This linear sensor is ratiometric, which is to say that for a variation of the supply voltage there is a variation proportional to the voltage of the output signal. The resolution of this sensor is infinite, which makes it possible to have an important sensitivity. In variable temperature conditions, the resistance of the potentiometer varies because of its temperature coefficient, while the voltage of the output signal remains unchanged, except for deviations as the expansion of system materials causes the cursor to move on the track.

In summary, the linear sensor makes it possible to measure the position of the interface supporting the wiper and the sensor body.



The DNA of tech.®

User Manual for Linear Sensor UIPMA / UFPMA

Memory Effect Phenomenon

For a long time of storage (customer equipment) or during the using of sensor, in case of frozen position, to avoid the phenomenon of memory effect of membrane (additional linearity error), the wiper has to be placed in a position out of the using travel. Please also note that this phenomenon of memory effect can be solved with alternative design (to consult us).

Recommended positions for storage:

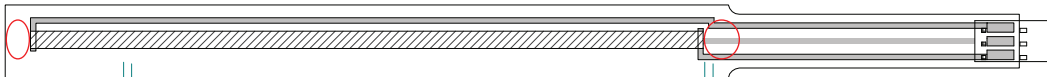

9. END OF LIFE

At the end of life, the product must be placed in ordinary industrial waste (OIW).