

Rotational Position Sensor, Kit Type, Hall Effect Technology



FEATURES

- Accurate linearity down to $\pm 0.5\%$
- All electrical angles available up to 360°
- Extremely long life: greater than 100M cycles
- Model dedicated to all applications in harsh environments
- Delivered as a kit: 2 elements
- Ideally suited for external applications: industrial or off-road markets
- Sealing level up to: IP68

QUICK REFERENCE DATA

Sensor type	Kit rotational, hall effect
Output type	Wires
Market appliance	Industrial
Dimensions	48 mm x 43 mm x 12 mm

ELECTRICAL SPECIFICATIONS

PARAMETER	STANDARD
Supply voltage, V_{supply}	$5\text{ V} \pm 0.5\text{ V}$ with regulator = 8 V to 16 V
Output mode	Analog or PWM CW or CCW
Electrical output range, V_{out}	for $V_{\text{supply}} 5\text{ V}$: 5 % to 95 % V_{supply} ratiometric for $V_{\text{supply}} < 11\text{ V}$: output from 0 V to $V_{\text{sub}} - 1\text{ V}$ for $V_{\text{supply}} > 11\text{ V}$: output from 0 V to 10 V max.
Electrical angle, Θ	any angle (1° to 360°)
Independent linearity	$A = \pm 1\%$ (V_{supply}) $B = \pm 0.5\%$ (V_{supply})
No load supply current, I_{supply}	< 16 mA single output < 32 mA redundant output
Over voltage protection - output enabled	for output (5 V): +20 V for output (10 V): 29 V
Reverse voltage protection - output disabled	for output (5 V): -10 V for output (10 V): -35 V
Temperature coefficient, $\Delta V_{\text{out}}/\Delta T$ (25 °C)	60 $\mu\text{V}/^\circ\text{C}$ typ.
Hysteresis	< 0.35°
Resolution	12 bits
Resistive load recommended	$R_{\text{pull-down}}$ OR $R_{\text{pull-up}}$: $V_{\text{out}} 5\text{ V}$ Min.: 1 k Ω Typ.: 10 k Ω
Capacitive load recommended	4.7 nF
Start up cycle	< 15 ms

MECHANICAL SPECIFICATIONS

PARAMETER	
Mounting type	2 oblong holes
Housing	plastic
Output type	single output: cable 3 x 0.35 mm ² redundant: cable 4 x 0.25 mm ² length: 400 mm min.

OUTPUT SPECIFICATIONS

For $V_{\text{supply}} = 5 \text{ V}$
 $V_{\text{out}} 0.25 \text{ V} \rightarrow 4.75 \text{ V}$

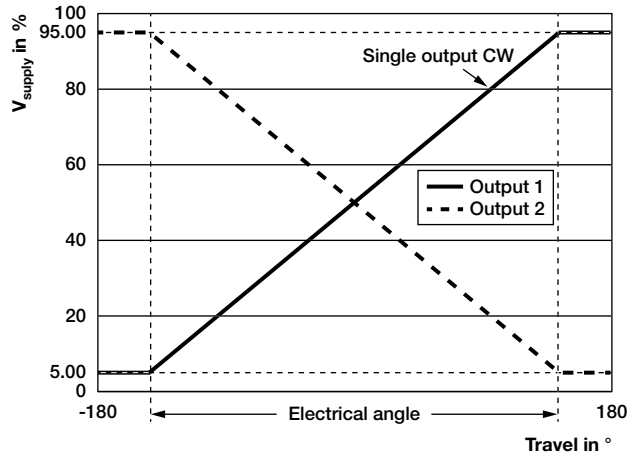
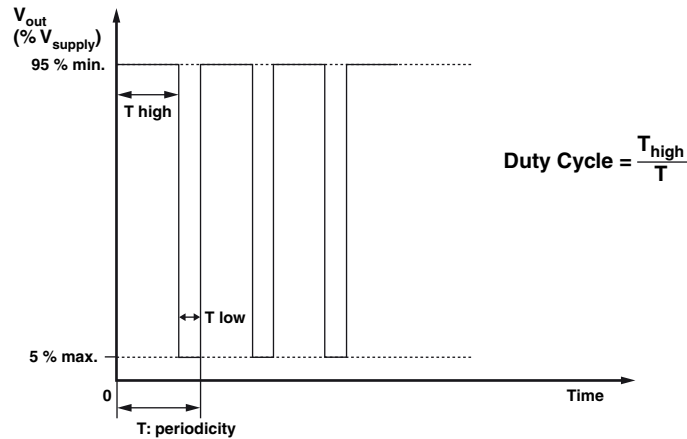
 V_{OUT} PWM

ENVIRONMENTAL SPECIFICATIONS

Life	unlimited mechanical lifetime
Rotation speed	120 rpm max.
Vibrations	20 g, 10 Hz to 2000 Hz EN60068-2-6
Shocks (1/2 sinus, 11 ms)	50 g EN60068-2-27
Operating temperature range	-45 °C; +105 °C
Storage temperature range	-45 °C; +105 °C
Sealing	IP67 (up to IP68)
Electrostatic discharges ESD	contact: $\pm 4 \text{ kV}$, air: $\pm 8 \text{ kV}$ EN61000-4-2
Radiated electromagnetic emissions	30 MHz to 1GHz EN61000-6-4
Immunity to radiated RF electromagnetic fields	10 V/m EN61000-4-3
	10 V/m, 900 MHz, heating 200 Hz EN61000-6-2 and EN50204
Immunity to radiated Electromagnetic disturbances	200 V/m, 150 kHz to 1 GHz IEC 62132-2 part 2
Immunity to power frequency magnetic field	150 G (15 mT) external field, DC and 50 Hz

Note

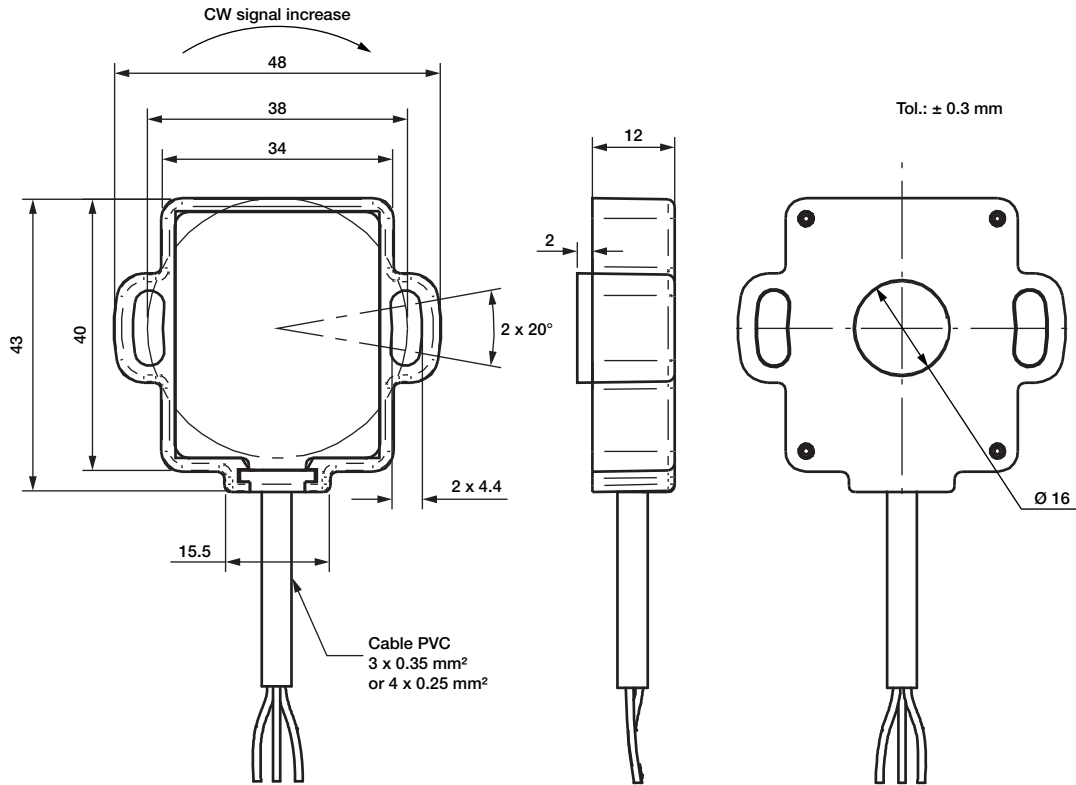
- Nothing stated herein shall be construed as a guarantee of quality or durability.

DIMENSIONS in millimeters

PINOUT	
Blue	signal 1
White	Gnd
Red	V+

PINOUT - Redundant version	
Blue	signal 1
White	Gnd
Red	V+
Yellow	signal 2

POSITION MARKERS

Position marker A (shaft Ø 4): ACAPTAXEW2566
 Position marker B (shaft Ø 6): ACAPTAXEW2567

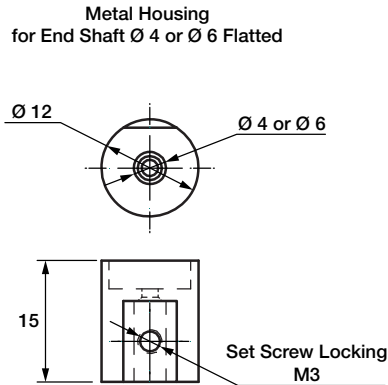

Position marker C: ACAPTAXEW2568

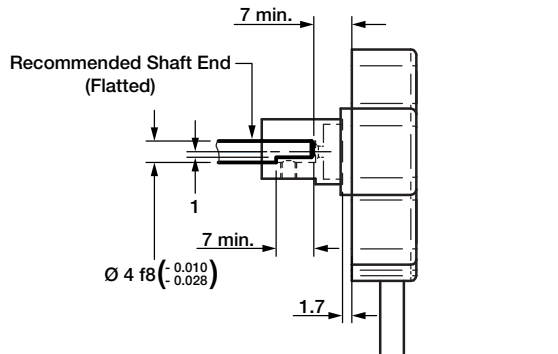
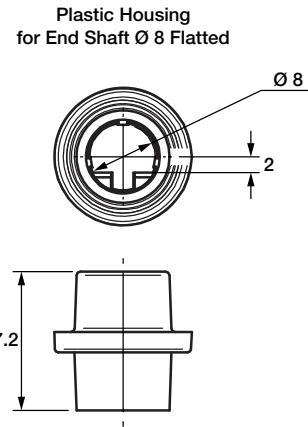

Shaft reference position: signal 1 = 50 %

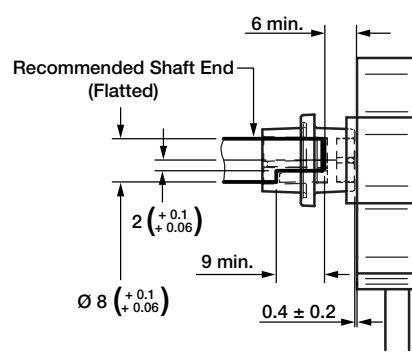

Shaft reference position: signal 1 = 50 %

SAP PART NUMBERING

SMHE	1	A	A	180	C	11	A	xxxx
MODEL	FEATURES		LINEARITY	ANGLE	OUTPUT TYPE		OUTPUT SIGNAL	SPECIAL REQUEST
	1: single output 2: redundant output	A: with positioning marker A B: with positioning marker B C: with positioning marker C X: without positioning marker Z: other (custom)	A: ± 1 % B: ± 0.5 %	045: 45° 090: 90° 120: 120° 180: 180° 270: 270° 360: 360° xxx: any angle	C: cable Z: other	11: in = 5 V; out = 5 V 21: in = 8 V to 16 V; out = 5 V 22: in = 11 V to 16 V; out = 10 V Z: other	A: analog CW B: analog CCW C: PWM CW D: PWM CCW E: analog crossed F: PWM crossed Z: other (custom)	0000



Disclaimer

ALL PRODUCT, PRODUCT SPECIFICATIONS AND DATA ARE SUBJECT TO CHANGE WITHOUT NOTICE TO IMPROVE RELIABILITY, FUNCTION OR DESIGN OR OTHERWISE.

Vishay Intertechnology, Inc., its affiliates, agents, and employees, and all persons acting on its or their behalf (collectively, "Vishay"), disclaim any and all liability for any errors, inaccuracies or incompleteness contained in any datasheet or in any other disclosure relating to any product.

Vishay makes no warranty, representation or guarantee regarding the suitability of the products for any particular purpose or the continuing production of any product. To the maximum extent permitted by applicable law, Vishay disclaims (i) any and all liability arising out of the application or use of any product, (ii) any and all liability, including without limitation special, consequential or incidental damages, and (iii) any and all implied warranties, including warranties of fitness for particular purpose, non-infringement and merchantability.

Statements regarding the suitability of products for certain types of applications are based on Vishay's knowledge of typical requirements that are often placed on Vishay products in generic applications. Such statements are not binding statements about the suitability of products for a particular application. It is the customer's responsibility to validate that a particular product with the properties described in the product specification is suitable for use in a particular application. Parameters provided in datasheets and / or specifications may vary in different applications and performance may vary over time. All operating parameters, including typical parameters, must be validated for each customer application by the customer's technical experts. Product specifications do not expand or otherwise modify Vishay's terms and conditions of purchase, including but not limited to the warranty expressed therein.

Hyperlinks included in this datasheet may direct users to third-party websites. These links are provided as a convenience and for informational purposes only. Inclusion of these hyperlinks does not constitute an endorsement or an approval by Vishay of any of the products, services or opinions of the corporation, organization or individual associated with the third-party website. Vishay disclaims any and all liability and bears no responsibility for the accuracy, legality or content of the third-party website or for that of subsequent links.

Except as expressly indicated in writing, Vishay products are not designed for use in medical, life-saving, or life-sustaining applications or for any other application in which the failure of the Vishay product could result in personal injury or death. Customers using or selling Vishay products not expressly indicated for use in such applications do so at their own risk. Please contact authorized Vishay personnel to obtain written terms and conditions regarding products designed for such applications.

No license, express or implied, by estoppel or otherwise, to any intellectual property rights is granted by this document or by any conduct of Vishay. Product names and markings noted herein may be trademarks of their respective owners.