

Cut Leads:
H = 9.1 mm, W = 5.4 mm, X = 6.55 mm

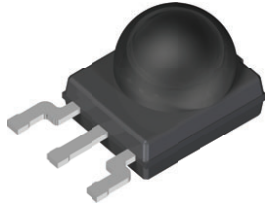

22951

AVAILABLE FOR

- Minimold

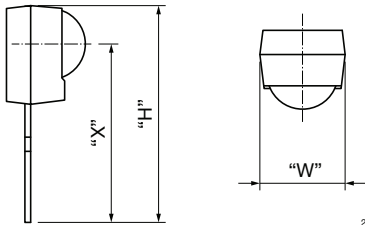

20258

LINKS TO ADDITIONAL RESOURCES

[Product Page](#)

[Calculators](#)

[Marking](#)

[Packages](#)

[Holders](#)

[Bends and Cuts](#)

NAME	LENS AXIS (X)	VIEW	TYPE	HEIGHT (H)	WIDTH (W)	DEPTH (D)
DO1	6.55	-	Cut	9.1	5.4	-



MECHANICAL DIMENSIONS in millimeters

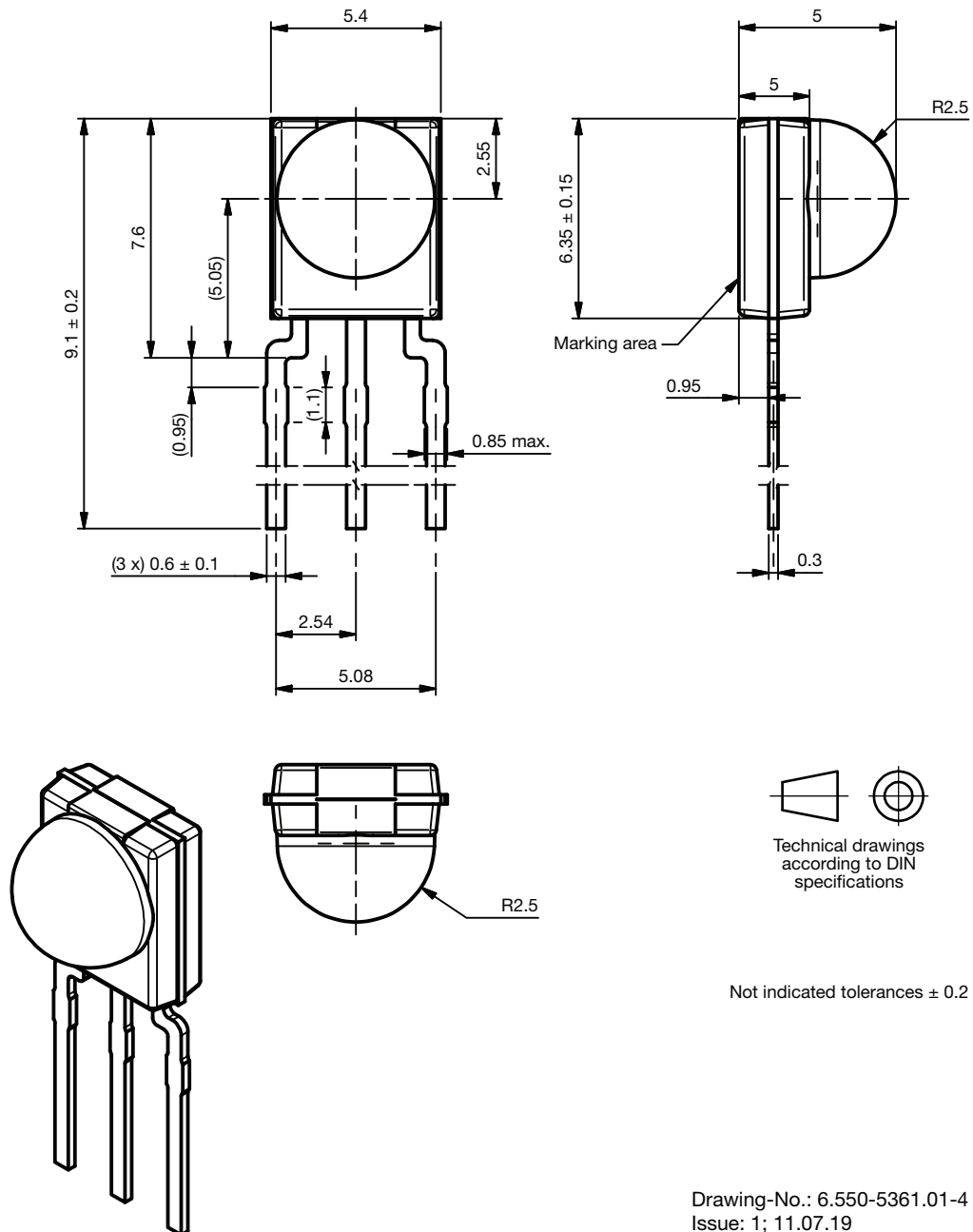

BULK PACKAGING

Standard shipping for minimold is in conductive plastic bags. The packing quantity is determined by weight and a maximum of 0.3 % of the components per carton may be missing.

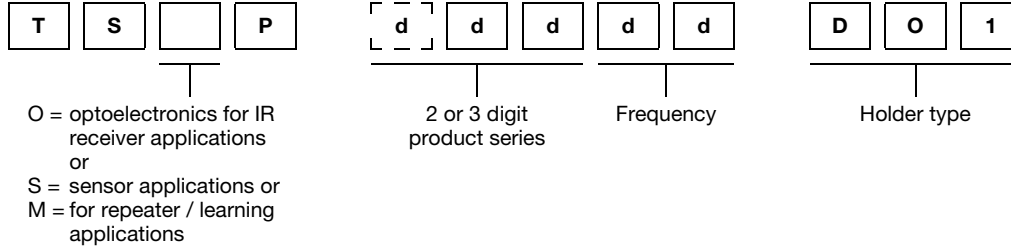
ORDERING INFORMATION

Note

- d = "digit", please consult the list of available series on the previous page to create a valid part number

Example: TSOP33336DO1

PACKAGING QUANTITY

- 300 pieces per bag (each bag is individually boxed)
- 6 bags per carton

OUTER PACKAGING

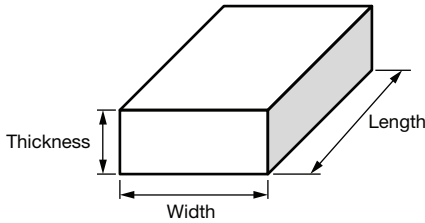
CARTON BOX DIMENSIONS in millimeters			
			
KINDS OF CARTON BOX	THICKNESS	WIDTH	LENGTH
Packaging plastic tubes (normal / auxiliary devices)	80	150	600
Packaging plastic trays (devices with metal holders)	120	290	490
Big box (bulk packaging)	150	180	400